

SD 280 螺紋管

產品圖

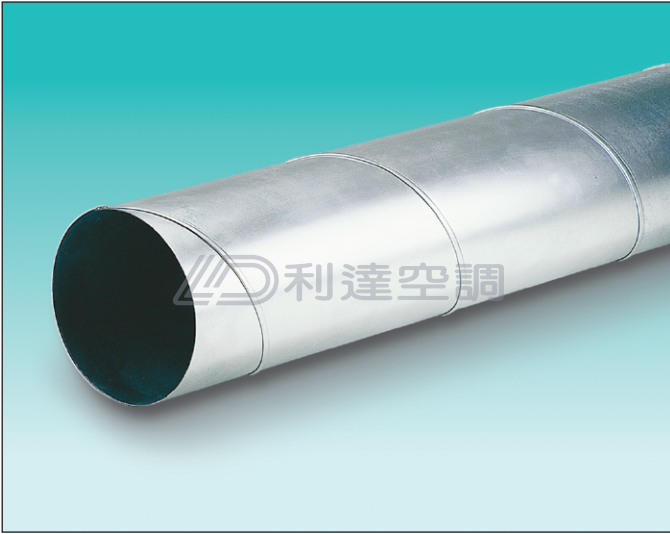

規格表

管徑 mm φD	長度 m L	厚度 t (mm)							
		0.5	0.6	0.8	1.0	1.2	1.5	2.0	2.5
150	3	○	●	○					
175	3	○	●	○	○				
200	3	○	●	○	○				
225	3		●	○	○	○			
250	3		●	○	○	○			
275	3		●	○	○	○			
300	3		●	○	○	○			
325	3		●	○	○	○	○		
350	3		●	○	○	○	○		
400	3		●	○	○	○	○		
450	3		○	●	○	○	○		
500	3			●	○	○	○	○	
550	3			●	○	○	○	○	
600	3			●	○	○	○	○	
650	3			●	○	○	○	○	
700	3			●	○	○	○	○	○
750	3			●	○	○	○	○	○
800	3			●	○	○	○	○	○
850	3			●	○	○	○	○	○
900	3			●	○	○	○	○	○
950	3			○	●	○	○	○	○
1000	3			○	●	○	○	○	○
1100	3				●	○	○	○	○
1200	3				●	○	○	○	○
1300	3				○	●	○	○	○
1400	3				○	●	○	○	○
1500	3					●	○	○	○
1600	3					●	○	○	○
1700	3					○	●	○	○
1800	3					○	●	○	○
1900	3						●	○	○
2000	3						●	○	○
2100	3						●	○	○
2200	3						○	●	○
2300	3						○	●	○
2400	3							●	○
2500	3							●	○
2600	3							●	○
2700	3							●	○
2800	3							●	○
2900	3							●	○
3000	3							●	○

產品說明

- 材質可選用鍍鋅鋼板(G)、不鏽鋼板(S)、烤漆鋼板(C)。
- 螺紋管厚度要求均可達到SMACNA規範。
- 較大節距(P=280 mm)螺紋管，周邊易於開孔，可配合如意三通使用。
- 管徑由150 mm至3000 mm。
- 節距大，接縫修長美觀，開孔容易，施工簡單，節省工資。
- 適合用於高速風管送排風、新鮮空氣、廢氣處理及集塵管等。

型號 SD280* -t-D
 材質 (G、S、C)
 板厚 (mm) t
 口徑 (mm) D

尺寸圖

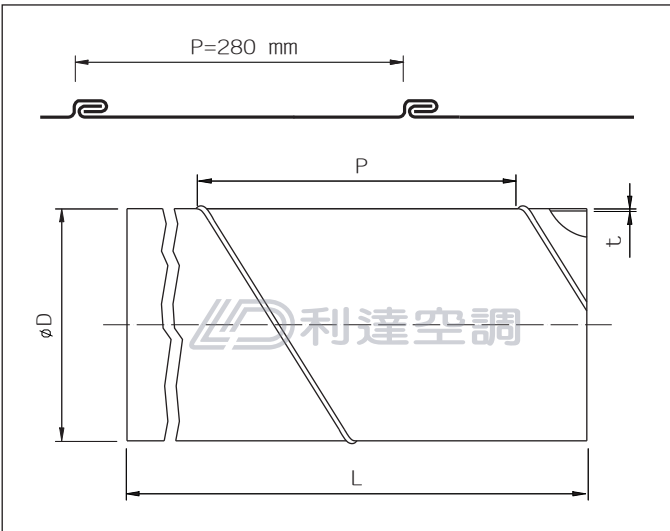

附註：● 為建議最小厚度，規格以外尺寸亦可訂做。