

EST 45 氬焊蝦節彎頭

產品圖

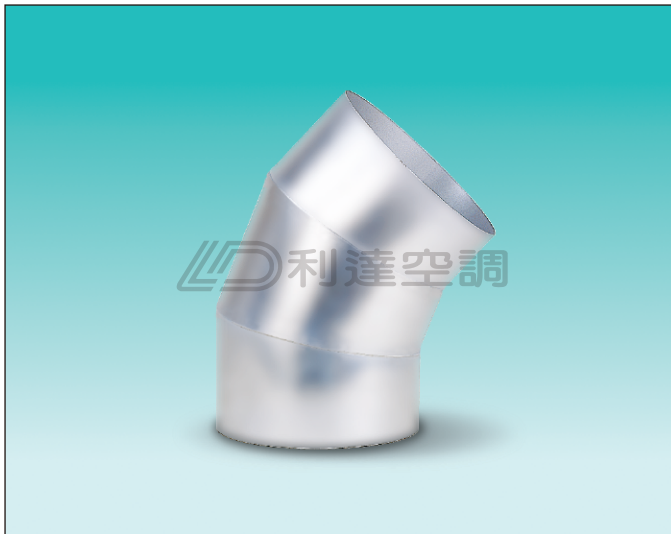

規格表

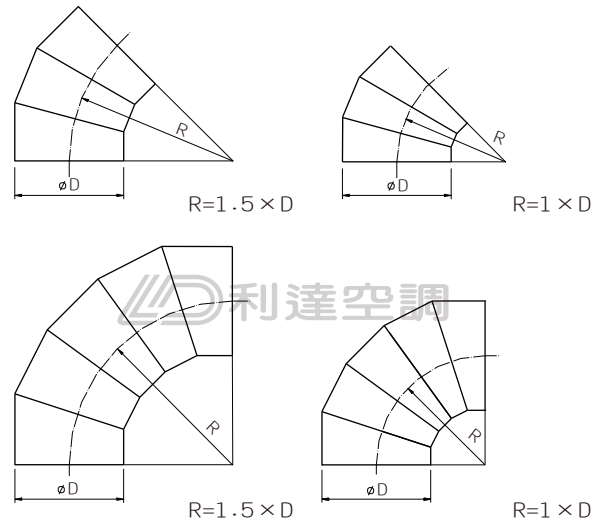

EST 90 氬焊蝦節彎頭

產品圖



口徑 φ D (mm)	內徑 R (mm)	45度 片數	90度 片數	厚度 t (mm)			
				1.0	1.2	1.5	2.0
250	1D	3	4	●	○	○	○
300	1D	3	4	●	○	○	○
350	1D	3	4	●	○	○	○
400	1D	3	5	●	○	○	○
450	1D	3	5	●	○	○	○
500	1D	3	5	●	○	○	○
550	1D	3	5	●	○	○	○
600	1D	3	5	●	○	○	○
650	1D	3	5	●	○	○	○
700	1D	3	5	●	○	○	○
750	1D	3	5	●	○	○	○
800	1D	3	5	●	○	○	○
850	1D	3	5	●	○	○	○
900	1D	3	5	○	●	○	○
950	1D	3	5	○	●	○	○
1000	1D	3	5	○	●	○	○
1100	1D	3	5		●	○	○
1200	1D	3	5		●	○	○
1300	1D	3	5		○	●	○
1400	1D	3	5		○	●	○
1500	1D	3	5		○	●	○
1600	1D	4	5		○	●	○
1700	1D	4	7		○	○	●
1800	1D	4	7		○	○	●
1900	1D	4	7		○	○	●
2000	1D	5	7		○	○	●

產品說明

- 材質可選用鍍鋅鋼板(G)或不鏽鋼板(S)。
- 以雷射切割出原形，再氬焊接合而成。
- 適合用於高氣密需求之送、排風管系統及半導體廠製程排氣管和Coating使用。
- 彎頭的口徑及角度準確，氣密100%。
- 特殊規格可依客戶需求訂製。
- 焊道採用平接焊。
- 連接方式採用平鐵法蘭或角鐵法蘭。

EST45/90 \* t-D

型號 \_\_\_\_\_  
 材質 (G、S) \_\_\_\_\_  
 板厚 (mm) t \_\_\_\_\_  
 口徑 (mm) D \_\_\_\_\_

附註：● 為建議厚度。  
 客戶需求與上表不同時，訂貨時請聲明。